

ASSEMBLY INSTRUCTIONS

ITEM DESCRIPTION:

| | |
|--|-----------------------|
| ITEM NO.: 49106 | NAME: Julius Sconce |
| MATERIAL TYPE: Alabaster, Steel FINISH: White, Antique Brass | |
| SOCKET TYPE: E12 | SOCKET QTY: 2 |
| BULB WATTAGE: 8W | |
| VOLTAGE: 110-120V | ITEM NET WEIGHT: 6LBS |



TO ASSEMBLE:

1. REMOVE ALL PACKING CONTENTS AND PARTS FROM THE CARTON(S) CAREFULLY
2. PLEASE BE SURE YOU HAVE ALL PARTS INDICATED BEFORE YOU BEGIN ASSEMBLY
3. SHUT OFF THE MAIN ELECTRICAL SUPPLY FROM THE MAIN FUSE BOX/CIRCUIT BREAKER.
4. REMOVE THE MOUNTING PLATE (A) FROM THE LAMP BODY(C) BY TURNING SET SCREW(B) IN AN ANTICLOCKWISE DIRECTION.
5. PULL THE ELECTRICAL CORD OF "J BOX" THROUGH THE EXIT HOLE OF THE MOUNTING PLATE(A)
6. CAREFULLY INSPECT THE FIXTURE WIRES. THE NEUTRAL FIXTURE WIRE HAS VERY FINE RIDGES MOLDED INTO ITS PLASTIC COVERING. THE HOT FIXTURE WIRE HAS A SMOOTH COVERING. THE BARE WIRE IS THE GROUNDED WIRE.
7. ATTACH THE GROUND WIRE FROM THE FIXTURE TO THE GROUND JUNCTION BOX WIRE FROM THE OUTLET (USUALLY GREEN OR BARE WIRE). FASTEN EACH TOGETHER WITH A PLASTIC WIRE CONNECTOR (K) AND WRAP THE CONNECTION WITH ELECTRICAL TAPE. IF YOUR OUTLET BOX DOES NOT HAVE A GROUND WIRE, INSERT THE GREEN GROUND SCREW INTO THE MOUNTING PLATE (A) FACING DOWN, AND WRAP THE FIXTURE'S BARE GROUND WIRE AROUND THE GROUND SCREW. IT IS IMPERATIVE THAT THE OUTLET BOX IN YOUR HOME BE PROPERLY GROUNDED.
8. CONNECT THE NEUTRAL FIXTURE WIRE TO THE NEUTRAL JUNCTION BOX WIRE (USUALLY WHITE). FASTEN EACH TOGETHER WITH A WIRE CONNECTOR (K) AND WRAP THE CONNECTION WITH ELECTRICAL TAPE. BE SURE NO STRANDS ARE EXPOSED.
9. CONNECT THE HOT FIXTURE WIRE TO THE HOT JUNCTION BOX WIRE (USUALLY BLACK). FASTEN EACH TOGETHER WITH A PLASTIC WIRE CONNECTOR (K) AND WRAP THE CONNECTION WITH ELECTRICAL TAPE. BE SURE NO WIRE STRANDS ARE EXPOSED. DO NOT REVERSE THE HOT AND NEUTRAL CONNECTIONS OR SAFETY WILL BE COMPROMISED.
10. GENTLY TUCK THE WIRE CONNECTIONS NEATLY INTO THE JUNCTION BOX.
11. ATTACH THE MOUNTING PLATE (A) TO THE OUTLET BOX BY USING THE MOUNTING SCREWS (J), TIGHTEN SCREWS (J) WITH A SCREWDRIVER.
12. ATTACH THE LAMP BODY (C) TO THE MOUNTING PLATE (A) BY USING THE ENCLOSED TURN-KNOBS (B). SECURE THE BACK PLATE BY TIGHTENING 2 TURN-KNOBS (B)
13. ATTACH SNOW MARBLE PANEL (D) & PLASTIC WASHER (G) INTO THREADED NIPPLE (F) OF THE LAMP BODY (C), AND THEN TIGHTEN 2 TURN-KNOBS (B) TO SECURE THE SNOW MARBLE.
14. INSERT 2 TYPE B MAX 8W LED BULBS ONLY (NOT INCLUDED) (H) INTO THE SOCKETS (E). DO NOT EXCEED SPECIFIED WATTAGE.
15. RESTORE POWER TO THE JUNCTION BOX AND TEST FIXTURE.

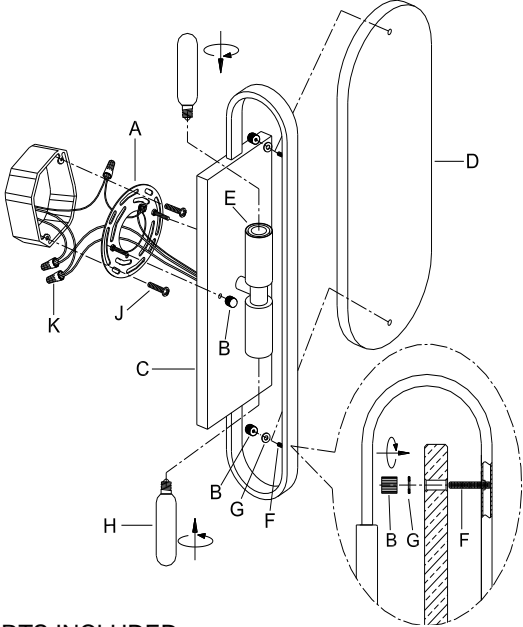

PARTS INCLUDED:

| | | | |
|-------------------|-------|-------------------|-------|
| A MOUNTING PLATE | 1 PC | E SOCKETS | 2 PCS |
| B TURN-KNOBS | 4 PCS | F THREADED NIP | 2 PCS |
| C LAMP BOEY | 1 PC | G PLASTIC WASHER | 2 PCS |
| D SNOW MARBLE PAN | 1 PC | H BULB (NOT INCL) | 2 PCS |

HARDWARE INCLUDED:

| | |
|------------------------|--------|
| Mounting Screws | Qty: 2 |
| Plastic Wire Connector | Qty: 1 |

TOOLS NEEDED (Not Included):

1 Screwdriver

These instructions are provided for safety. It is very important that they are read carefully and completely before beginning installation of this chandelier.

We strongly suggest that all hard-wired fixtures must be installed by a professional electrician.

CARE INSTRUCTIONS:

Wipe with a soft, dry cloth. To protect finish, avoid the use of chemicals and household cleaners.

For customer service questions call 1-800-338-2150

ARTERIOURS