

ASSEMBLY INSTRUCTIONS

ITEM DESCRIPTION:

ITEM NO.: 49870	NAME: Watson Sconce
MATERIAL TYPE: Steel	FINISH: Taupe, Antique Brass
SOCKET TYPE: E26	SOCKET QTY: 1
BULB WATTAGE: 60 W	
VOLTAGE: 110-120 V	ITEM NET WEIGHT: 3.5 LBS

PARTS INCLUDED:

Mounting Plate	Qty: 1 Pc
Back Plate	Qty: 1 Pc
Shade	Qty: 1 Pc

HARDWARE INCLUDED:

Mounting Screws (C)	Qty: 2 Pcs

TOOLS NEEDED (Not Included):

1 Screwdriver

These instructions are provided for safety. It is very important that they are read carefully and completely before beginning installation of this chandelier.

We strongly suggest that all hard-wired fixtures must be installed by a professional electrician.

For customer service questions call 1-800-338-2150



TO ASSEMBLE:

1. Shut off the main electrical supply from the main fuse box/circuit breaker.
2. Attach mounting plate to wall or junction box using mounting screws (C).
3. Connect ground wire from wall to ground wire from lamp using wire caps (A).
4. Attach house wire to lamp wires as shown. Fasten the pairs together with a wirecaps. **DO NOT REVERSE THE HOT AND NEUTRAL CONNECTIONS OR SAFETY WILLBE COMPROMISED.**
5. Attach front face of light to back plate by inserting canopy screws (B) through predrilled holes in front face and into back plate as shown. Tighten using screwdriver.
6. Insert light bulb.
7. Restore power to junction box and test fixture.
DO NOT EXCEED SPECIFIED MAX WATTAGE.

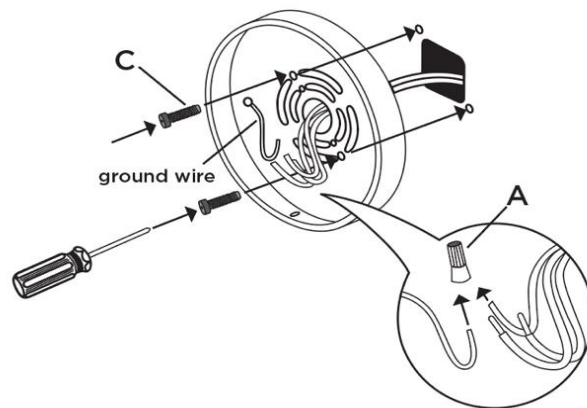

CARE INSTRUCTIONS:

Wipe with a soft, dry cloth. To protect finish, avoid the use of chemicals and household cleaners.

ARTERIOS