

ASSEMBLY INSTRUCTIONS

ITEM DESCRIPTION:

ITEM NO.:DWC89	NAME: LUNA SCONCE
MATERIAL TYPE: IRON, ALUMINUM	FINISH: MATTE BLACK
SOCKET TYPE: : LED	SOCKET QTY: 1
BULB WATTAGE: 8W	
VOLTAGE: 100V-120V	ITEM NET WEIGHT: 18.7LBS

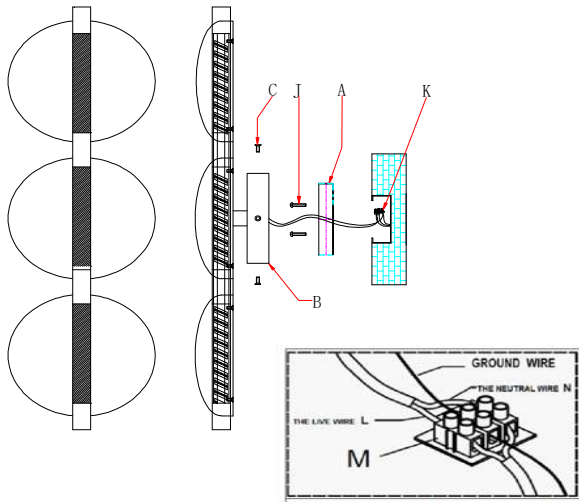

PLEASE IGNORE THIS DEVICE ON THE BACK PLATE.

PARTS INCLUDED:

Mounting Plate(A)	Qty: 1PC
Back Plate(B)	Qty: 1PC

HARDWARE INCLUDED:

Mounting Screw(J)	Qty: 2PCS
Canopy Screw(C)	Qty: 2PCS
Green Ground Screw	Qty: 1PC
Plastic Wire Connector(K)	Qty: 3PCS

TOOLS NEEDED (Not Included):

1 Screwdriver

These instructions are provided for safety. It is very important that they are read carefully and completely before beginning installation.

We strongly suggest that all hard-wired fixtures must be installed by a professional electrician.

For customer service questions call 1-800-338-2150



TO ASSEMBLE:

1. Shut off the main electrical supply from the main fuse box/circuit breaker.
2. Carefully unpack all fixture parts and hardware and lay them on a soft surface for assembly.
3. Gently pull wiring down from junction box and allow to hang.
4. Remove the mounting plate(A) from the back plate(B) by loosening the canopy screw (C) using a Phillips screwdriver.
5. Place the mounting plate(A) over the center of the junction box.
6. Align the holes in the mounting plate (A) with the holes in the junction box and secure it with two mounting screws (J). Secure the screws using a Phillips head screwdriver.
7. Connect ground wire from wall to ground wire from lamp using wire caps (K).
8. Attach house wire to lamp wires as shown. Fasten the pairs together with a wire caps. DO NOT REVERSE THE HOT AND NEUTRAL CONNECTIONS OR SAFETY WILL BE COMPROMISED.
9. PLEASE PAY SPECIAL ATTENTION TO THE FACT THAT YOU DO NOT NEED TO CONNECT THE WIRE TO THE DEVICE (M). IT IS USED FOR WIRE CONNECTIONS IN THE EUROPEAN MARKET.
10. Please note that this product is suitable for 0-10V dimmer switches. Connect the purple wire (+) and the gray wire (-) to the dimmer switch as shown in Figure 1. BE SURE NO STRANDS ARE EXPOSED.
11. Gently tuck the wire connections(K) neatly into the junction box.
12. Attach the back plate(B) to the mounting plate (A) with 2 canopy screws (C), and tighten with a screwdriver.
13. Restore power to junction box and test fixture.

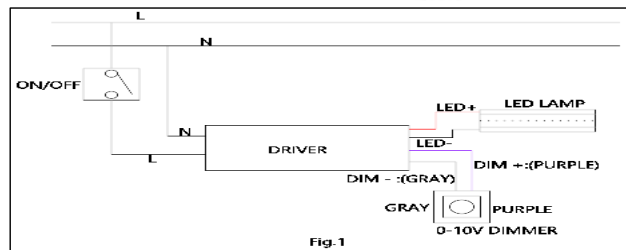
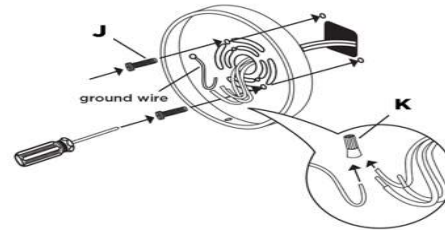

CARE INSTRUCTIONS:

Wipe with a soft, dry cloth. To protect finish, avoid the use of chemicals and household cleaners.

ARTERIO RS