

ARTERIOS

ANDERSON SMALL PENDANT

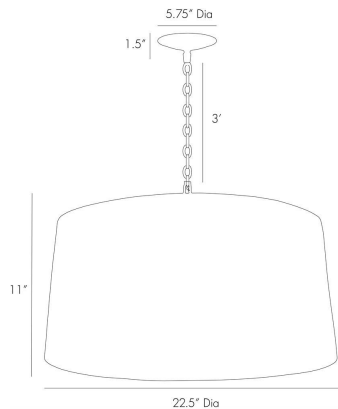

42466
English Bronze, Iron

3-light hand hammered iron drum shade pendant in a bronze finish both on exterior and interior, features a double diffuser suspended from within. Perforated metal bottom allows light to illuminate and suspends from matching linked chain. Additional chain available CHN-946. Certified for damp locations and intended for interior use.

APPEARANCE

Materials	Iron, Iron
Finishes	English Bronze, English Bronze
Finish Will Vary	No
Top Coat/Sealant	No

DIMENSIONS

Overall	Dia: 22.5 in x H: 11 in
Canopy	Dia: 5.75 in x H: 1.5 in
Overall Hanging Height as Sold (in)	47 in - 11 in

WIRING

Wire Rating	Damp
Cord	9 FT, Clear/Silver, SVT
Socket	3, Type A- E26 Keyless
Suggested Bulb Type	B8
Maximum Wattage	40.0
Voltage	110-120 V

CERTIFICATIONS & COMPLIANCY

Certifications	Middle East, European Union, United Kingdom, Mexico, United States, Canada
Compliance	RoHS, UL/ETL, CB

SHIPPING

Product Weight	15.0 lbs
Gross Weight 1	27.8 lbs
Shipping Box 1	W: 26.0 in x D: 26.0 in x H: 14.0 in

CONTRACT

Contract Suitability	Contract Suitable As Is
----------------------	-------------------------

SLOPE CEILING COMPATIBILITY

Sloped Ceiling Compatible	Yes, as is
---------------------------	------------

COMPONENTS

Pipe or Chain Included	36"
------------------------	-----

ADDITIONAL PARTS AVAILABLE

CHN-946	36"
---------	-----

REPLACEMENT PARTS

CANOPY-946
42466DIF