

ARTERIOS

HARRINGTON COUNTER STOOL

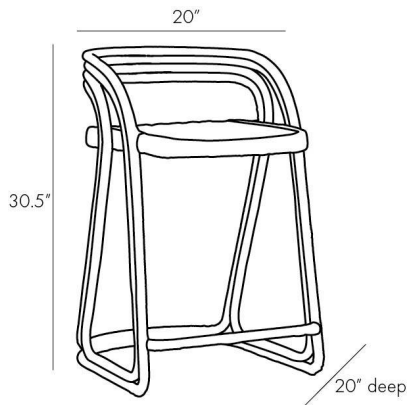

5632
Moth Gray, Rattan

Organic materials and handcrafted construction rise to the occasion to complete the natural presentation of this counter stool. Crafted entirely of rattan, the Harrington features a hand-woven seat styled in the traditional cane pattern and a frame wrapped in rattan peel. A moth gray finish refines its rustic aesthetic and enhances its natural characteristics. With no arms and a slightly curved back, this stool easily slides under any counter. Finish will vary.

APPEARANCE

Materials	Rattan, Rattan
Finishes	Moth Gray, Moth Gray
Finish Will Vary	Yes
Top Coat/Sealant	Yes

DIMENSIONS

Overall	W: 20 in x D: 20 in x H: 30.5 in
Foot Print	W: 20 in x D: 20 in
Clearance	H: 5 in
Seat	W: 17 in x D: 16 in x H: 24 in

SHIPPING

Shipping Requirements	Truck Ship
Product Weight	22.1 lbs
Gross Weight 1	27.56 lbs
Shipping Box 1	W: 24.0 in x D: 22.5 in x H: 34.5 in

CONTRACT

Contract Suitability	Contract Suitable With Conditions
Contract Conditions	Not for use in high traffic/public spaces