

ARTERIOS

NOLAN LARGE PENDANT

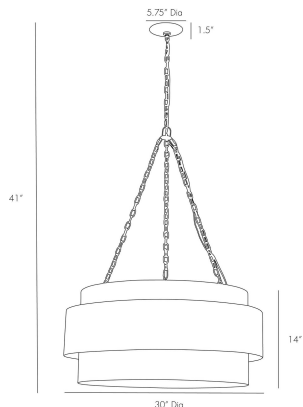

84015
Antique Brass, Iron

This iron, mid-century-inspired, four-light vintage brass-finished pendant is the perfect light to hang over a dining table. The dark, bronze, floating band adds contrast and dimensionality to the simple elegant design. A tri-chain mount blends seamlessly with the metallic finish. Additional chain available CHN-885.

APPEARANCE

Materials	Iron, Iron, Iron
Finishes	Antique Brass, Bronze, Antique Brass
Finish Will Vary	No
Top Coat/Sealant	Yes

DIMENSIONS

Overall	Dia: 30.0 in x H: 41 in
Canopy	Dia: 5.75 in x H: 1.5 in
Pendant	Dia: 30.0 in x H: 14 in
Overall Hanging Height as Sold (in)	41 in - 77 in

WIRING

Wire Rating	Indoor Only
Cord	10 FT, Clear/Silver, SVT
Socket	4, Type A- E26 Keyless
Suggested Bulb Type	G25
Maximum Wattage	60.0
Voltage	110-120 V

CERTIFICATIONS & COMPLIANCY

Certifications	Middle East, European Union, United Kingdom, Mexico, United States, Canada
Compliance	RoHS, UL/ETL, CB

SHIPPING

Product Weight	23.5 lbs
Gross Weight 1	48.5 lbs
Shipping Box 1	W: 35.0 in x D: 35.0 in x H: 19.0 in

CONTRACT

Contract Suitability	Contract Suitable As Is
----------------------	-------------------------

SLOPE CEILING COMPATIBILITY

Sloped Ceiling Compatible	Yes, as is
---------------------------	------------

ADDITIONAL PARTS AVAILABLE

CHN-885	36"
---------	-----

REPLACEMENT PARTS

CHN-885
