

# ARTERIO RS

## GRIFFITH CHANDELIER

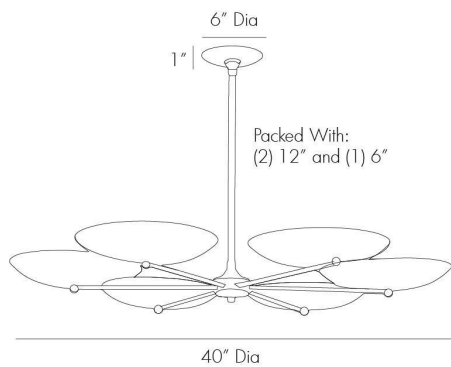

89047  
Antique Brass, Steel

Delicate in nature, the Griffith chandelier balances a severe bronze finish with an elegant antique brass frame. The bronze plates face upwards, diffusing the light and creating a warm, even glow. Certified for damp locations and intended for interior use. finish will vary. Additional pipe available (PIPE-101).

### APPEARANCE

|                  |  |
|------------------|--|
| Materials        | Steel, Steel, Steel, Steel                 |
| Finishes         | Antique Brass, Bronze, Matte White, Bronze |
| Finish Will Vary | No   |
| Top Coat/Sealant | Yes  |

### DIMENSIONS

|                                     |                         |
|-------------------------------------|-------------------------|
| Overall                             | Dia: 40.0 in x H: 11 in |
| Canopy                              | Dia: 6.0 in x H: 1 in   |
| Chandelier                          | Dia: 40.0 in x H: 4 in  |
| Overall Hanging Height as Sold (in) | 35 in - 11 in           |

### WIRING

|                     |                          |
|---------------------|--------------------------|
| Wire Rating         | Damp                     |
| Cord                | 10 FT, Clear/Silver, SVT |
| Socket              | 6, Type B--E12 Other     |
| Suggested Bulb Type | G16.5                    |
| Maximum Wattage     | 40.0                     |
| Voltage             | 110-120 V                |

### CERTIFICATIONS & COMPLIANCY

|                |   |
|----------------|---|
| Certifications | Middle East, European Union, United Kingdom, Australia, Mexico, United States, Canada |
| Compliance     | RoHS, UL/ETL, CB  |

### SHIPPING

|                |                                     |
|----------------|-------------------------------------|
| Product Weight | 14.3 lbs                            |
| Gross Weight 1 | 22.66 lbs                           |
| Shipping Box 1 | W: 42.5 in x D: 38.5 in x H: 5.7 in |

### CONTRACT

|                      |                         |
|----------------------|-------------------------|
| Contract Suitability | Contract Suitable As Is |
|----------------------|-------------------------|

### SLOPE CEILING COMPATIBILITY

|                           |                             |
|---------------------------|-----------------------------|
| Sloped Ceiling Compatible | Yes, with purchase of pivot |
|---------------------------|-----------------------------|

### COMPONENTS

|                        |                 |
|------------------------|-----------------|
| Pipe or Chain Included | (1) 6", (2) 12" |
|------------------------|-----------------|

### ADDITIONAL PARTS AVAILABLE

|           |                 |
|-----------|-----------------|
| PIPE-101  | (1) 6", (1) 12" |
| PIVOT-203 |                 |

### REPLACEMENT PARTS

|            |  |
|------------|--|
| CANOPY-108 |  |
| 89047FIN   |  |