

ARTERIOS

ESTRIBO PENDANT

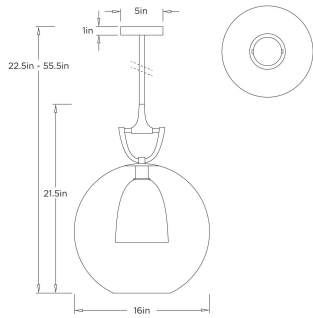

*ADDITIONAL PIPE AVAILABLE
DPI15 ESTRIBO PENDANT ARTERIOS



DPI15
Clear, Glass

Drawing inspiration from the sculptural geometry of an equestrian horse bit, the Estribo Pendant reinterprets classic bridle hardware through a refined, architectural lens. Crafted in antique brass, its interlocking curves and balanced proportions echo the strength and precision of traditional tack while transforming the form into a statement of modern elegance. The warm, hand-finished metal highlights the rhythmic interplay of line and negative space, creating a sophisticated focal point that feels both heritage-driven and distinctly

APPEARANCE

Materials	Glass, Brass, Glass
Finishes	Clear, Antique Brass, Frosted
Finish Will Vary	Yes
Top Coat/Sealant	No

DIMENSIONS

Overall	Dia: 16 in x H: 22.5 in
Body	Dia: 16 in x H: 22.5 in
Globe	Dia: 16 in x H: 15.5 in
Canopy	Dia: 5 in x H: 1 in
Overall Hanging Height as Sold (in)	22.5 in

WIRING

Wire Rating	Indoor Only
Cord	10.5 FT, Black, SVT
Socket	1, Type A - E26
Suggested Bulb Type	G25
Maximum Wattage	25
Voltage	110-120 V

SHIPPING

Product Weight	15 lbs
Gross Weight 1	23 lbs
Shipping Box 1	W: 21 in x D: 29 in x H: 21 in

ADDITIONAL INFO

Features	Assembly Required
----------	-------------------

CONTRACT

Contract Suitability	Contract Suitable As Is
----------------------	-------------------------

COMPONENTS

Pipe or Chain Included	(1) 3", (1) 6", (2) 12"
------------------------	-------------------------

ADDITIONAL PARTS AVAILABLE

PIPE-144	(1) 6", (1) 12"
----------	-----------------