

ARTERIOS

ROSEMONT LARGE PENDANT

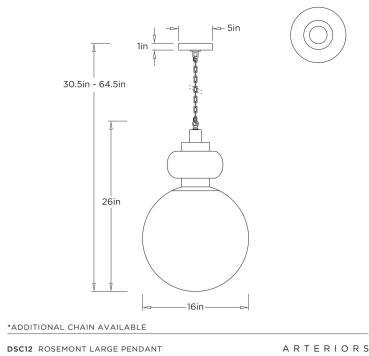

DSC12
Matte Swirl, Glass

This pendant casts a soft glow of luxurious matte swirl glass, topped with white alabaster. Rendered in a totemic silhouette, the Rosemont is accented with an English bronze-plated iron band and decorative rectangular chain links. Certified for damp locations and intended for interior use. Finish will vary.

APPEARANCE

Materials	Glass, Alabaster, Iron
Finishes	Matte Swirl, White, English Bronze
Finish Will Vary	Yes
Top Coat/Sealant	Yes

DIMENSIONS

Overall	Dia: 16.0 in x H: 30.5 in
Canopy	Dia: 5.0 in x H: 1 in
Pendant	Dia: 16.0 in x H: 26 in
Overall Hanging Height as Sold (in)	63 in - 30.5 in

WIRING

Wire Rating	Damp
Cord	10 FT, Black/White, SVT
Socket	1, Type A - E26
Suggested Bulb Type	G40
Maximum Wattage	60.0
Voltage	110-120 V

CERTIFICATIONS & COMPLIANCY

Compliance	RoHS
------------	------

SHIPPING

Product Weight	29.0 lbs
Gross Weight 1	34.0 lbs
Shipping Box 1	W: 30.0 in x D: 19.5 in x H: 20.5 in

CONTRACT

Contract Suitability	Contract Suitable As Is
----------------------	-------------------------

SLOPE CEILING COMPATIBILITY

Sloped Ceiling Compatible	Yes, as is
---------------------------	------------

ADDITIONAL PARTS AVAILABLE

CHN-274	36"
---------	-----

REPLACEMENT PARTS

DSC12GLS