

# ARTERIOS

## DAGMAR CONSOLE

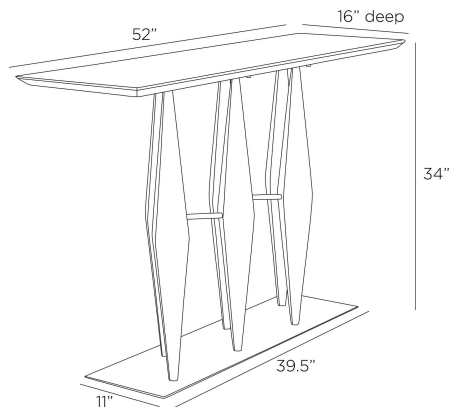

FLI09  
Matte Black, Marble

An Aztec-inspired console makes a timeless statement. Reminiscent of prisms or spears, the geometric antique gold base is topped with a slim surface of matte black marble. Marble veining will vary.

### APPEARANCE

Materials	Marble, Iron
Finishes	Matte Black, Antique Gold
Finish Will Vary	Yes
Top Coat/Sealant	Yes

### DIMENSIONS

Overall	W: 52 in x D: 16 in x H: 34 in
Foot Print	W: 39.5 in x D: 11 in
Table Top	W: 52 in x D: 16 in x H: 1 in
Diagonal Dimensions	W: 38 in

### SHIPPING

Shipping Requirements	Special Handling Required
Product Weight	162.7 lbs
Gross Weight 1	75.8 lbs
Gross Weight 2	109.8 lbs
Shipping Box 1	W: 37.0 in x D: 15.5 in x H: 43.5 in
Shipping Box 2	W: 9.0 in x D: 21.75 in x H: 56.5 in

### ADDITIONAL INFO

Features	Assembly Required
----------	-------------------

### CONTRACT

Commercial Maintenance	Check all hardware connections periodically to ensure they are tightened.
Contract Suitability	Contract Suitable With Conditions
Contract Conditions	Natural stone requires periodic sealing, For an additional fee, a clear, protective coating can be added