

ARTERIOS

ALJONA SWIVEL CHAIR CREAM

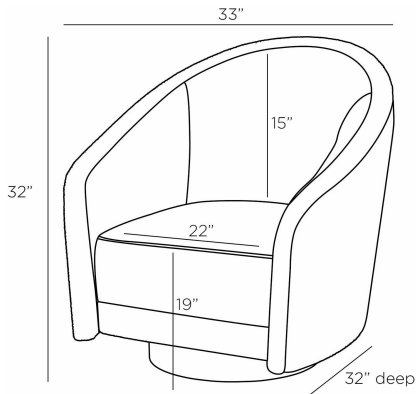

FRU05
Cream, Sherpa

This cream sherpa design is designed to cradle like a hug, providing welcoming comfort to any room. A fully upholstered barrel is wrapped with luxurious oyster leather about the sides and back for textural interest. A recessed champagne finished plinth iron base anchors the chair while concealing a 360-degree swivel mechanism. Leather will vary.

APPEARANCE

Materials	Sherpa, Leather, Iron
Finishes	Cream, Oyster, Champagne
Finish Will Vary	Yes
Top Coat/Sealant	No

DIMENSIONS

Overall	W: 33 in x D: 32 in x H: 32 in
Foot Print	Dia: 19.0 in
Base	H: 4.5 in
Seat Back	W: 19 in x D: 10.5 in x H: 15 in
Seat	W: 22 in x D: 20 in x H: 19 in
Diagonal Dimensions	W: 45.5 in

SHIPPING

Shipping Requirements	Special Handling Required
Product Weight	67.2 lbs
Gross Weight 1	92.2 lbs
Shipping Box 1	W: 32.0 in x D: 33.0 in x H: 32.0 in

ADDITIONAL INFO

Disclaimers	This piece is made with genuine leather. The variations in color are a natural characteristic of leather and may increase over time, adding to the individuality of your item. Please keep this away from prolonged intense sunlight, heat and humidity.
-------------	--

Fabric Certification	NFPA-260, TB117-2013
Fabric Composition	94% Polyester, 6% Acrylic
Fabric Cleaning Code	S - dry clean only
Fabric Wear Abrasion	15,000
Reupholstery Requirements	5 Yards 75 Square Feet
Base/Foot Type	360 Swivel Mechanism, Nylon Glides

CONTRACT

Contract Suitability	Contract Suitable As Is
Contract Textile Suitability	Low Traffic/Private Spaces

SWATCHES

T23SW	4x4 Swatch: Oyster Leather
X72SW	4x4 Swatch: Cream Sherpa