

# ARTERIOS

## FENDER LAMP

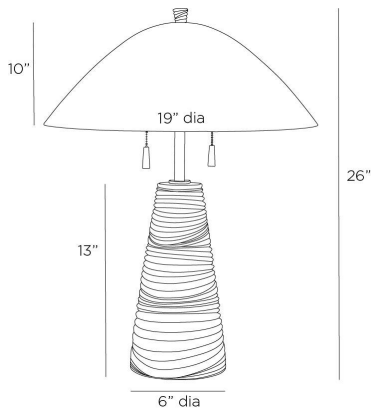

PTC50  
Black, Lava Stone

Crafted of black lava stone composite, the Fender has an eroded, ridged surface that lends textural intrigue. A helmet-like shade of bronze-plated steel reflects light to lend a moody vibe to any surface. Matching swirl texture finial and double bronze pull chains.

### APPEARANCE

Materials	Lava Stone, Steel, Steel
Finishes	Black, Bronze, Bronze
Finish Will Vary	No
Top Coat/Sealant	Yes

### DIMENSIONS

Overall	Dia: 19.0 in x H: 26 in
Foot Print	Dia: 6.0 in
Body	Dia: 6.0 in x H: 13 in
Finial	Dia: 1 in x H: 1 in
Shade Side	H: 10 in
Shade Bottom	Dia: 19.0 in
Neck	Dia: 1.0 in x H: 6 in

### WIRING

Wire Rating	Indoor Only
Cord	8 FT, Black Cloth, SPT-2
Socket	2, Type A - E26
Suggested Bulb Type	A19
Switch	At Socket, On/Off Pull Chain
Maximum Wattage	60.0
Voltage	110-120 V

### CERTIFICATIONS & COMPLIANCY

Certifications	Middle East, European Union, United Kingdom, Australia, Mexico, United States, Canada
Compliance	RoHS, UL/ETL, CB

### SHIPPING

Product Weight	21.5 lbs
Gross Weight 1	30.0 lbs
Shipping Box 1	W: 24.0 in x D: 16.5 in x H: 22.5 in

### CONTRACT

Contract Suitability	Contract Suitable As Is
Tilt Test Degrees	10 Degrees

### REPLACEMENT PARTS

PTC50FIN