

ARTERIOS

JEROME STOOL

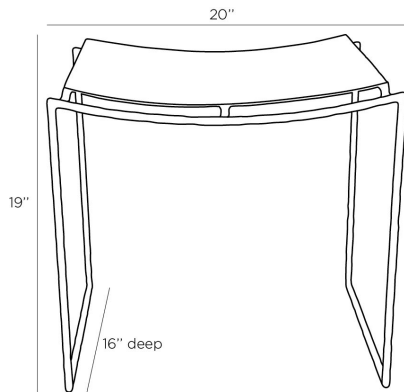

2086

H: 19 IN, W: 20 IN, D: 16 IN

Blackened

Contract Recommendations: Adding a lacquer coating provides additional pro-

The Jerome is defined by its industrial yet sculptural profile. Hand-hammered blackened iron frame and seat with a sling-inspired silhouette. Forged connections between the seat and legs showcase its handcrafted nature. Hammering in iron will vary.

APPEARANCE

Material	Iron
Material Type	Hammered
Finish	Blackened Iron
Finish Will Vary	true
Top Coat/Sealant	true

DIMENSIONS

Foot Print	W: 20 IN, D: 16 IN
Seat	W: 18 IN, D: 15.5 IN
Seat Height	18 IN
Seat	W: 18 IN, D: 15.5 IN

SHIPPING

Product Weight	22 LBS
Gross Weight 1	26.46 LBS
Shipping Box 1	H: 19 IN, L: 19 IN, W: 21 IN

CONTRACT

Contract Suitable	Adding a lacquer coating provides additional protection
-------------------	---