

ARTERIOS

ISAIAH OTTOMAN

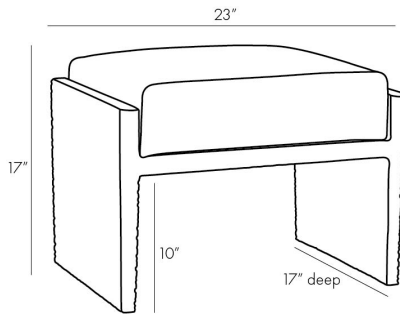

4892
H: 17 IN, W: 23 IN, D: 17 IN
Graphite Leather
Contract Suitable As Is

A plush graphite leather cushion seamlessly blends into a solid wood base for an unassuming seat. Hand-carved details create a textured motif that sweeps across the frame, which has a waxed black finish for a slight sheen that refines its rustic aesthetic. This practical piece is perfect peeking out from under a console, pulled up to a vanity or next to a lounge chair.

APPEARANCE

Material	Leather, Wood
Finish	Graphite, Handcarved Soft Black Waxed
Top Coat/Sealant	false
Textile Contract Suitability	High Traffic/Public Spaces

DIMENSIONS

Foot Print	W: 23 IN, D: 17 IN
Clearance	10 IN
Seat Cushion Thickness	5.5 IN

SHIPPING

Product Weight	24.25 LBS
Gross Weight 1	35.27 LBS
Gross Weight 2	0 LBS
Shipping Box 1	H: 18 IN, L: 18 IN, W: 27 IN
Shipping Box 2	H: 0 IN, L: 0 IN, W: 0 IN

ADDITIONAL INFO

Fabric Compliancy	NFPA-260, TB117-2013
Fabric Rub Count	N/A
Swatch Number	
Fabric Cleaning Code	Leather Cleaner
Fabric Content	100% Leather
Yardage To Reupholster	10 Square Feet 0.55 Yards

CONTRACT

Contract Suitable	true
Fabric Composition	100% Leather