

# ARTERIOS

## GLAZE LINEAR PENDANT

WORKSHOP

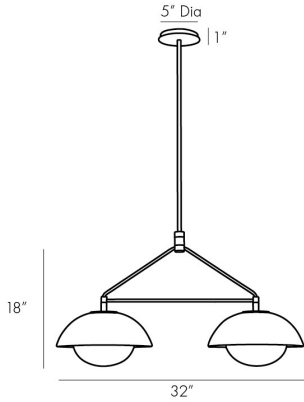

DA49001

H: 45 IN, W: 32 IN, D: 12 IN

Blackened Steel, Ivory Stained Crackle

Ceramic

Contract Suitable As Is

The Glaze collection is an ode to hand craftsmanship, inspired by beautiful glazed tableware and ceramics that reveal the hand of the maker. The Glaze Linear Pendant's super geometric blackened steel armature - elevated by textural knurled detailing - is paired with rounded ceramic shades in a unique ivory stained crackle glaze and soft frosted glass that casts a flattering glow. A showstopper designed to hold its own, the glaze pendant also offers endless installation possibilities when hung in multiples or with coordinating single glaze pendants for large spaces and public installations. Additional pipe available PIPE-465 Damp-rated, although limited covered outdoor areas may affect finish.

### APPEARANCE

Material	Ceramic, Glass, Steel
Material Type	Frosted
Finish	Blackened Steel, Ivory Stained Crackle, Opal
Finish Will Vary	true
Top Coat/Sealant	false

### DIMENSIONS

Chandelier	12.00
Minimum Hanging Height	H: 18 IN, W: 32 IN, D: 12 IN
Maximum Hanging Height	45 IN
Canopy	71 IN
	H: 1 IN, Dia: 5.00 IN

### WIRING

Rating	Damp
Cord	7 FT, Black, SVT
Socket	2, Type A - E26
Maximum Watt	40
Voltage	110-120 V

### CERTIFICATIONS

Certifications	Mexico Australia, European Union, United Arab Emirates, United States, Canada
----------------	--

### COMPLIANCY

UL/ETL	Yes
CB	Yes
RoHS	true

### SHIPPING

Product Weight	16 LBS
Gross Weight 1	22 LBS
Gross Weight 2	0 LBS
Shipping Box 1	H: 30 IN, L: 25.5 IN, W: 12 IN
Shipping Box 2	H: 0 IN, L: 0 IN, W: 0 IN

### REPLACEMENT PARTS

Replacement Part 1	PIPE-465
Replacement Part 1 Dim	(1) 6", (1) 12"
Replacement Part 2	CANOPY-481
Replacement Part 2 Dim	.5" x 5.5"

### CONTRACT

Contract Suitable	true
-------------------	------